

GROUNDWATER TREATMENT BY USING OZONE



PRINCIPLE

Ozone is highly-reactive, strong-oxidizing gas with standard potential +2,07 V. By ozonization of water, dissociation of hard-degradable components i.e. pesticides, polychlorinated biphenyls or chlorinated hydrocarbons can be achieved.

The crucial condition for effective application of the technology is supplying ozone-containing gas into intensive contact with contaminants contained in contaminated water. We use injector known also as Venturi tube for this purpose.

The instability of ozone requires the gas to be generated immediately prior to application. Ozone generator is thus with other technical equipment placed in a shipping container that can be easily installed on the site to be remediated. This technology is patented under the name "MNB OZONE".



Venturi tube

DESCRIPTION

Mobile technological system „MNB OZONE“ consists of ozone generator, Venturi tubes ensuring creation of bubbles and micro-nano bubbles in water, pumps, measuring instruments and controlling units and also injection and monitoring wells.



TECHNOLOGY APPLICABILITY

The technology is suitable for in situ remediation of groundwater and soils in saturated zone contaminated with organic substances. The instability of ozone requires its production immediately before its application. The ozone generator is one of the components of technical and measuring equipment in the mobile container, which can be installed on site. This technology was patented as "MNB OZONE".

Main advantages of the technology

- Applicability for wide spectra of organic contaminants
- No materials or wastes requiring further processing are produced by the technology
- Mobile and fully automatic operation only with occasional inspection

Potential limitations

- Increased content of some ions restrains required decomposition of contaminants
- Can be time consuming (from months to years)

Services and products

- Investigation and evaluation of contaminated sites
- Laboratory tests effectiveness of ozone micro-nano bubbles
- Project design and approval
- Remediation system installation, operation and monitoring
- Supervision of the remediation projects

Data for technology design

- Exact groundwater composition
- Required target contaminant concentration
- Geological and hydrogeological conditions on site
- Required remediation time

REFERENCE PROJECT

The technology was successfully full-scale tested on Velká Hleďsebe site, contaminated by chlorinated ethylene. The contamination originates from former degreasing station, level of contamination varied from 5 to 33 mg/L.

Well logging showed sandy clay backfill of thickness 1.1 m, then to the depth of 4.7 m were quaternary sediments and to the final depth of the well (14.2 m) were eluvia schists. Water flow through the well was approx. 15 L/day and the groundwater level varied from 5 to 6 m b.g.l.

The tests were held in 10 different campaigns with total duration of approx. 5 months. At the end of every campaign, the contamination concentration decreased below detection limit.

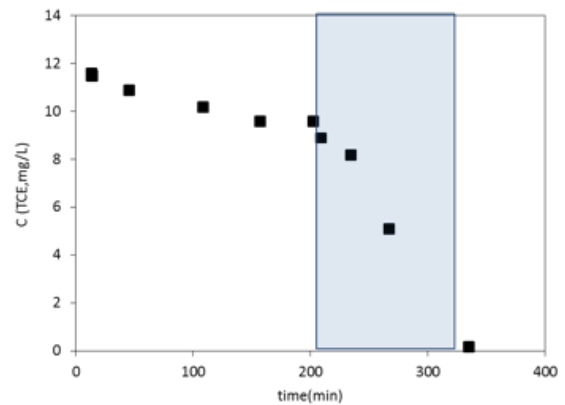

Trichloroethylene concentrations in monitoring well during one of the campaigns, blue colour marks ozone application

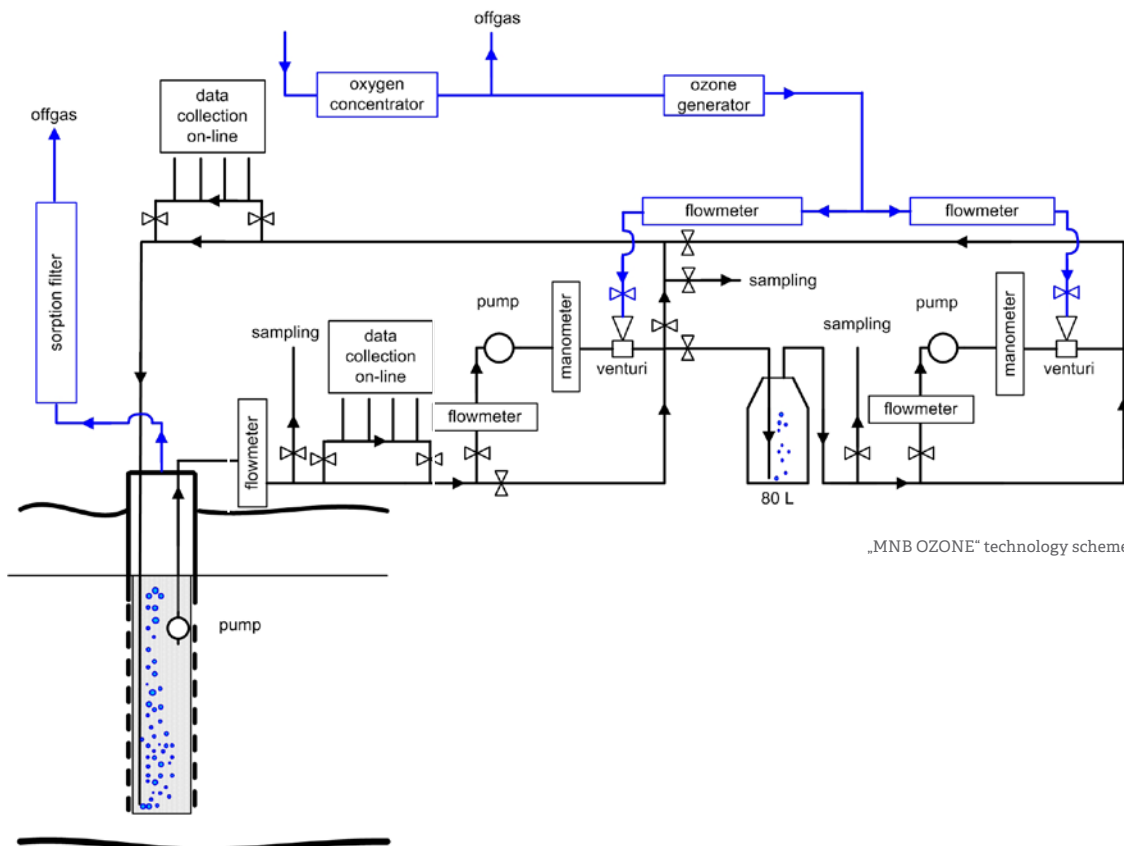

„MNB OZONE“ technology scheme